

LOC-LINE®

hadice pro chladicí kapaliny



NOGA chladič systém

2008

KLÍČEM SYSTÉMU LOC-LINE JE JEDNODUCHOST A ÚČELNÝ TVAR

- hadice LOC-LINE se dodávají ve 4 velikostech (1/4", 1/2", 3/4" a 2 1/2").
- ke všem velikostem nabízíme široký výběr ventilů, trysek a spojů.



- hadice se skládají z jednotlivých segmentů a proto jsou velmi flexibilní.
- hadice lze ručně ohýbat a nastavit je tak do požadované polohy. Díky segmentům je délka přizpůsobitelná aktuální potřebě.
- časté ohýbání nezpůsobuje zmenšování vnitřního průměru ani únavu materiálu.
- hadice jsou odolné proti vibracím a pozičně stabilní.
- hadice LOC-LINE jsou vyrobeny z kvalitního Acetalcopolymery, který je chemicky odolný vůči ropným produktům, chladicím kapalinám a běžným chemikáliím. Některé díly LOC-LINE se vyrábí i v provedení odolném proti kyselinám (žlutá barva).
- hadice LOC-LINE jsou navrženy na nízký tlak. Maximální tlak je závislý na délce hadice, průměru, zvolené trysce a úhlu ohybu.

Největší rozměr 2 1/2" představují sací hadice.

LOC-LINE[®] hadice pro chladicí kapaliny

HODNOTY TLAKU A PRŮTOKU:

Velikost 1/4": 30–50 PSI / 2,07–3,45 bar / 2,04–3,4 atm – 946 l/hod.

Velikost 1/2": 20–30 PSI / 1,38–2,07 bar / 1,36–2,04 atm – 1809 l/hod.

Velikost 3/4": 10–20 PSI / 0,69–1,38 bar / 0,68–1,36 atm – 4315 l/hod.

Výše uvedené hodnoty jsou orientační.
Použití hadic LOC-LINE je různorodé.
Použití v nestandardních podmínkách,
může ovlivnit hodnoty maximálního tlaku
a proto se před vlastním použitím
doporučuje zkouška.



MEZNÍ TEPLoty:

Bod tavení: 165 °C

Maximální pracovní teplota: 76 °C

BALENÍ A ROZMĚRY:

Jedotlivé díly a segmenty prodáváme po 1 ks případně v sadách.

Orientační údaje:

1/4" segmenty: 1 m = 70 segmentů
1 cívka = 1100 segmentů (cca 15 m)

1/2" segmenty: 1 m = 46 segmentů
1 cívka = 708 segmentů (cca 15 m)

3/4" segmenty: 1 m = 42 segmentů
1 cívka = 648 segmentů (cca 15 m)



Slučitelnost standardního provedení LOC-LINE (modro – oranžová barva)

Ano	Aceton
Ne	Kyseliny
Ano	Alkohol, Etyl
Ne	Hydroxid amonný (silná koncentrace)
Ne	Zásady (silná koncentrace)
Ano	Běžné mycí prostředky
Ano	Benzín
Ano	Tuky
Ne	Chlornan
Ano	Rozpouštědla, Ředidla
Ano	Oleje
Ano	Hydroxid sodný
Ne	Chlornan sodný

Kat. ozn.	Popis
40413	1/4" Sada Obsahuje: 20x segment 49421.1 1x tryska 49422.1 1x tryska 49423.1 1x tryska 49424.1 1x NPT hrdlo 49425.1 1x NPT hrdlo 49426.1
40452	1/4" Sada Obsahuje: 80x segment 49421.1 4x tryska 49423.1 4x tryska 49424.1 1x plochá tryska 49427.1 4x redukce 49432.1
41474	1/4" Sada trysky 90° Obsahuje: 1x tryska 90° 49439.1 1x tryska 90° 49440.1 1x tryska 90° 49441.1 1x tryska 90° plochá 49442.1
41475	1/4" Sada Obsahuje: 4x prodloužený segment 49445.1 4x svorka 49446.1
41479	1/4" Sada bočních trysky Obsahuje: 15x boční tryska 49443.1 1x záslepka 49447.1

Kat. ozn.	Popis
41487	1/4" Sada plochých trysky Obsahuje: 1x štěrbinová tryska 49451.1 1x štěrbinová tryska 49452.1 1x 5ti tryska 49453.1 1x 7mi tryska 49454.1
41490	1/4" Kompletní sada trysky Obsahuje: 1 ks od každé trysky 1/4" (celkem 16 trysky)
49421.1	1/4" segment (1 cívka = 1100 segmentů)
49445.1	1/4" prodloužený segment
49446.1	1/4" svorka
49422.1	1/4" tryska Ø 1,59 mm
49423.1	1/4" tryska Ø 3,18 mm
49424.1	1/4" tryska Ø 6,35 mm
49439.1	1/4" tryska 90° Ø 1,59 mm
49440.1	1/4" tryska 90° Ø 3,18 mm
49441.1	1/4" tryska 90° Ø 6,35 mm
49442.1	1/4" tryska 90° plochá
49427.1	1/4" plochá tryska

Kat. ozn.	Popis
	49425.1 1/4" hrdlo se závitem NPT 1/8"
	49437.1 1/4" hrdlo se závitem BSPT 1/8"
	49426.1 1/4" hrdlo se závitem NPT 1/4"
	49438.1 1/4" hrdlo se závitem BSPT 1/4"
	49428.1 1/4" Y rozdvojka
	49429.1 1/4" spojka (1/4" : 1/4")
	49431.1 1/4" redukce FNPT 1/8"
	49432.1 1/4" redukce SAE 3/8" 5/8-18
	49434.1 1/4" redukce SAE 1/4" 7/16-20
	49435.1 1/4" koleno
	49436.1 1/4" T redukce
	49443.1 1/4" boční tryska
	49447.1 1/4" záslepka
	49449.1 1/4" naklápěcí 16ti tryska 1 tryska Ø 1,02 mm
	49450.1 1/4" naklápěcí 16ti tryska 1 tryska Ø 1, 52 mm
	49455.1 1/4" naklápěcí 20ti tryska 1 tryska Ø 1, 91 mm
	49456.1 1/4" proudová tryska

Kat. ozn.	Popis
	29452.1 1/4" ventil s vnějším závitem NPT
	29453.1 1/4" ventil s vnitřním závitem NPT
	29454.1 1/4" mezisegmentový ventil
	29451.1 1/4" jednosměrný průtokový ventil
	49451.1 1/4" štěrbinová tryska šířka štěrbin 1,02 mm
	49452.1 1/4" štěrbinová tryska šířka štěrbin 1,52 mm
	49453.1 1/4" rozprašovací 5ti tryska 1 tryska Ø 1,52 mm
	49454.1 1/4" rozprašovací 7mi tryska 1 tryska Ø 1,02 mm
	78001 1/4" spojovací a rozpojovací kleště
	78003 sada spojovacích a rozpojovacích kleští (1/4" a 1/2")

vnitřní průměr 1/4":

- max. pracovní tlaky:
1/4" hadice: 30 PSI
1/4" mezisegmentový ventil: 30 PSI
1/4" ventily: 100 PSI
- materiál: acetyl copolymer – tělo,
Nitril (Buna N) – uzávěr
- otočením ventilu o 90° dojde k jeho uzavření





NPT = americký standard
BSPT = evropský standard, odpovídá G

**PODROBNÉ ROZMĚRY K VELIKOSTI 1/4"
NA STRANĚ 10-11**

Kat. ozn.	Popis
50813	1/2" Sada Obsahuje: 12x segment 59861.1 1x tryska 59866.1 1x tryska 59862.1 1x tryska 59863.1 1x NPT hrdlo 59864.1 1x NPT hrdlo 59865.1
51832	1/2" Sada trysek 90° Obsahuje: 1x tryska 90° 59878.1 1x tryska 90° 59879.1 1x tryska 90° 59880.1 1x tryska 90° plochá 59881.1
51835	1/2" Sada Obsahuje: 4x prodloužený segment 59883.1 4x svorka 59884.1
51837	1/2" Sada bočních trysek Obsahuje: 15x boční tryska 59889.1 1x záslepka 59885.1
51844	1/2" Sada plochých trysek Obsahuje: 1x štěrbinová tryska 59890.1 1x štěrbinová tryska 59891.1 1x 5ti tryska 59892.1 1x 7mi tryska 59893.1

Kat. ozn.	Popis
41490	1/2" Kompletní sada trysek Obsahuje: 1 ks od každé trysky 1/2" (celkem 16 trysek)
59861.1	1/2" segment (1 cívka = 708 segmentů)
59883.1	1/2" prodloužený segment
59884.1	1/2" svorka
59866.1	1/2" tryska Ø 6,35 mm
59862.1	1/2" tryska Ø 9,53 mm
59863.1	1/2" tryska Ø 12,70 mm
59878.1	1/2" tryska 90° Ø 6,35 mm
59879.1	1/2" tryska 90° Ø 9,53 mm
59880.1	1/2" tryska 90° Ø 12,70 mm
59881.1	1/2" tryska 90° plochá
59867.1	1/2" plochá tryska
59871.1	1/2" plochá tryska
59864.1	1/2" hrdlo se závitem NPT 3/8"
59876.1	1/2" hrdlo se závitem BSPT 3/8"
59865.1	1/2" hrdlo se závitem NPT 1/2"

Kat. ozn.	Popis
	59877.1 1/2" hrdlo se závitem BSPT 1/2"
	59868.1 1/2" Y rozdvojka
	59870.1 1/2" Y rozdvojka z 1/2" na 1/4"
	59869.1 1/2" redukce na 1/4"
	59872.1 1/2" spojka (1/2" : 1/2")
	59873.1 1/2" redukce SAE 3/8" 5/8-18
	59874.1 1/2" koleno
	59875.1 1/2" T redukce
	59889.1 1/2" boční tryska
	59885.1 1/2" zásepka
	59895.1 1/2" naklápěcí 20ti tryska 1 tryska Ø 1,91 mm
	39851.1 1/2" jednosměrný průtokový ventil
	59897.1 1/2" proudová tryska
	59898.1 1/2" proudová tryska
	39852.1 1/2" ventil s vnějším závitem NPT
	39853.1 1/2" ventil s vnitřním závitem NPT
	39854.1 1/2" mezisegmentový ventil
	59890.1 1/2" štěrbinová tryska šířka štěrbin 2,03 mm

Kat. ozn.	Popis
	59891.1 1/2" štěrbinová tryska šířka štěrbin 3,18 mm
	59892.1 1/2" rozprašovací 5ti tryska 1 tryska Ø 3,18 mm
	59893.1 1/2" rozprašovací 7mi tryska 1 tryska Ø 2,03 mm
	78002 spojovací a rozpojovací kleště 1/2" 78003 sada spojovacích a rozpojovacích kleští (1/4" a 1/2")
	59896.1 1/2" přípojka na hadici
	51846 1/2" magnetická základna

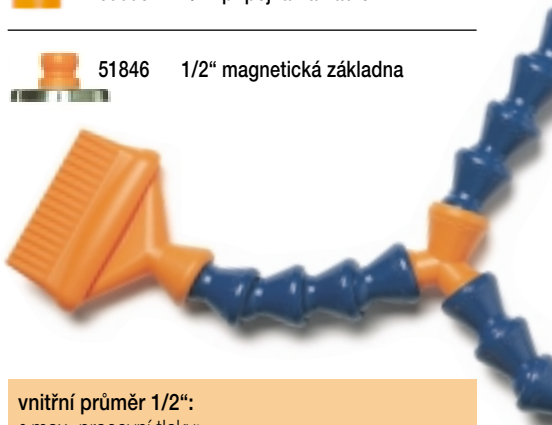

vnitřní průměr 1/2":

- max. pracovní tlaky:
1/2" hadice: 20 PSI
1/2" mezisegmentový ventil: 20 PSI
1/2" ventily: 100 PSI
- materiál: acetyl copolymer – tělo,
Nitril (Buna N) – uzávěr
- otočením ventilu o 90° dojde k jeho uzavření

NPT = americký standard
BSPT = evropský standard, odpovídá G

**PODROBNÉ ROZMĚRY K VELIKOSTI 1/2"
NA STRANĚ 12-13**

3/4" HADICE A DOPLŇKY

Kat. ozn.	Popis
60513	3/4" Sada Obsahuje: 12x segment 69541.1 1x tryska 69543.1 1x tryska 69542.1 1x NPT hrdlo 69545.1
69541.1	3/4" segment (1 cívka = 648 segmentů)
69543.1	3/4" tryska Ø 15,88 mm
69542.1	3/4" tryska Ø 19,05 mm
69547.1	3/4" plochá tryska
69545.1	3/4" hrdlo se závitem NPT 3/4"
69549.1	3/4" hrdlo se závitem BSPT 3/4"
69551.1	3/4" Y rozdvojka
69552.1	3/4" Y redukce z 3/4" na 1/2"
69548.1	3/4" redukce na 1/2"
69554.1	3/4" spojka (3/4" : 3/4")
69555.1	3/4" koleno

vnitřní průměr 3/4":

- max pracovní tlak:
3/4" hadice: 0,68 atm
3/4" mezisegmentový ventil: 0,68 atm
3/4" ventily: 3,40 atm
(3/4" hadice snižuje tlak u většiny aplikací na 0,68 atm)
- materiál: acetyl copolymer – tělo,
Nitril (Buna N) – uzávěr
- otočením ventilu o 90° dojde k jeho uzavření

Kat. ozn.	Popis
69556.1	3/4" ventil s vnějším závitem NPT
69557.1	3/4" ventil s vnitřním závitem NPT
69558.1	3/4" mezisegmentový ventil

OCHRANNÉ ŠTÍTY A DOPLŇKY

Poskytují ochranu proti odletujícím tříškám a stříkající kapalině. Štít je možné otočit o 360°. Vyrobeno z polykarbonátu (tloušťka 3,2 mm). Ochranná vrstva na magnetu zabraňuje zachytávání třísek.

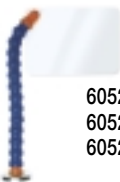

SADY S OCHRANNÝM ŠTÍTEM

- | | |
|-------|------------------------|
| 60525 | Sada se štítem 60528.1 |
| 60526 | Sada se štítem 60529.1 |
| 60527 | Sada se štítem 60530.1 |
- Sady obsahují:
1x štít (velikost viz výše)
14x segment 69541.1
1x magnetická základna 60532.1
1x upevňovací koleno 60531.1

NÁHRADNÍ OCHRANNÉ ŠTÍTY

- | | |
|---------|---------------------|
| 60528.1 | štít 15,25x20,30 cm |
| 60529.1 | štít 19,05x25,40 cm |
| 60530.1 | štít 21,60x30,50 cm |

60531.1	3/4" upevňovací koleno včetně podložky a šroubku
60532.1	3/4" magnetická základna
60533.1	3/4" přípojka na hadici
78004.1	3/4" spojovací a rozpojovací kleště

NPT = americký standard
BSPT = evropský standard, odpovídá G

**PODROBNÉ ROZMĚRY K VELIKOSTI 3/4"
NA STRANĚ 14**

Kat. ozn. Popis

- 21199** 1/4" Základní rozvaděč
Obsahuje:
3x T redukce 49436.1
1x koleno 49435.1
1x montážní deska 21195.1
3x šroub



- 21198** 1/4" Kompletní rozvaděč
Obsahuje:
1x zákl. rozvaděč 21199
5x meziseg. ventil 29454.1



- 21195.1** 1/4" montážní deska



- 49435.1** 1/4" koleno



- 49436.1** 1/4" T redukce



- 32099** 1/2" Základní rozvaděč
Obsahuje:
3x T redukce 59875.1
1x koleno 59874.1
1x montážní deska 32095.1
3x šroub



- 32098** 1/2" Kompletní rozvaděč
Obsahuje:
1x zákl. rozvaděč 32099
5x meziseg. ventil 39854.1



- 32095.1** 1/2" montážní deska



- 59874.1** 1/2" koleno



- 59875.1** 1/2" T redukce



Kat. ozn. Popis

- 40480** 1/4" Sada s magnetickým rozvaděčem – velká
Obsahuje:
8x segment 49421.1
5x ventil 29452.1
2x plochá tryska 49427.1
2x tryska 49424.1
2x tryska 49423.1
2x tryska 49422.1
1x magnet. základna 40400.1



- 40463** 1/4" Sada s magnetickým rozvaděčem – malá
Obsahuje:
2x segment 49421.1
1x ventil 29452.1
1x plochá tryska 49427.1
1x tryska 49424.1
1x tryska 49423.1
1x tryska 49422.1
1x magnet. základna 40400.1





- 40400.1** 1/4" magnetická základna k rozvaděči
Obsahuje:
4x 1/4" výstup
1x 1/4" vstup



ROZVADĚČE S MAGNETICKOU ZÁKLADNOU



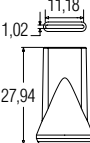
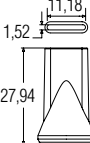
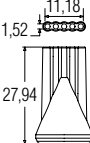
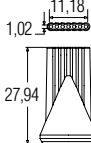
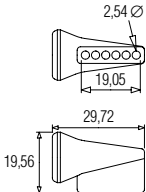
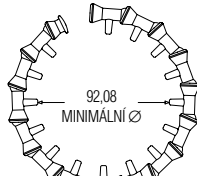
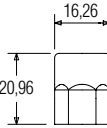
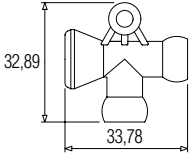
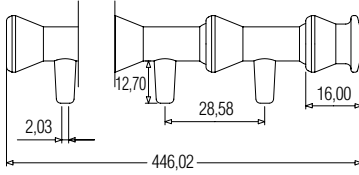
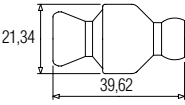
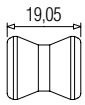
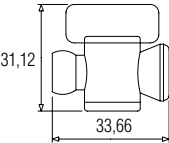
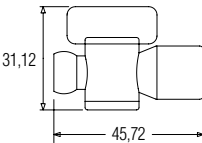
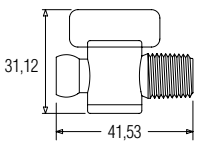
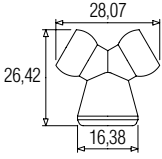
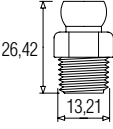
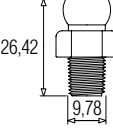

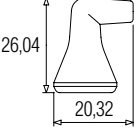
Umožňují rozvod chladicí kapaliny z jednoho zdroje do 4 ramen zároveň. Magnetická základna umožňuje větší spektrum upnutí a tím lepší přístup k předmětu chlazení. Otvor 1/4" umožňuje upnout jakýkoli díl o velikosti 1/4".

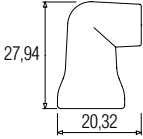
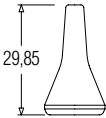
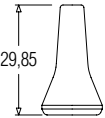
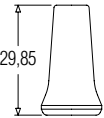
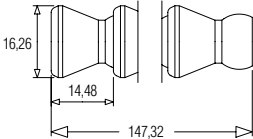
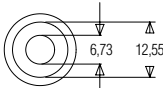
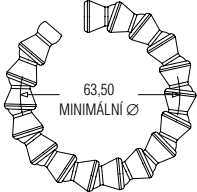
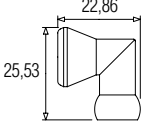
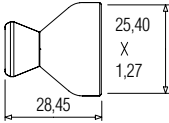
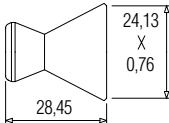
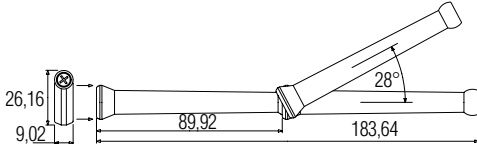
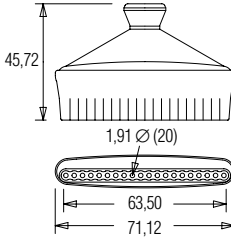
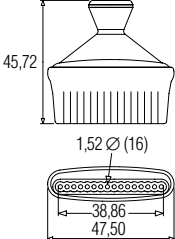
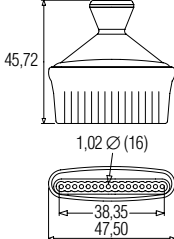

1/4" HADICE PODROBNÉ ROZMĚRY

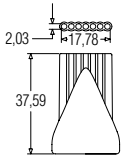
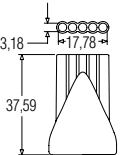
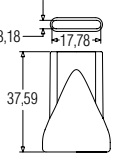
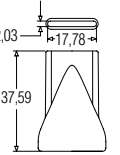
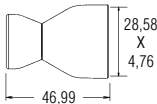
<p>1/4" štěrbínová tryska 49451.1</p> 	<p>1/4" štěrbínová tryska 49452.1</p> 	<p>1/4" rozprašovací 5ti tryska 49453.1</p> 	<p>1/4" rozprašovací 7mi tryska 49454.1</p> 
<p>1/4" tryska 90° plochá 49442.1</p> 	<p>1/4" sada bočních trysek 41479</p> 	<p>1/4" redukce FNPT 1/8" 49431.1</p> 	<p>1/4" T redukce 49436.1</p> 
<p>1/4" sada bočních trysek 41479</p> 		<p>1/4" jednosměrný průtokový ventil 29451.1</p> 	<p>1/4" spojka (1/4":1/4) 49429.1</p> 
<p>1/4" mezisegmentový ventil 29454.1</p> 	<p>1/4" ventil s vnitřním závitem NPT 29453.1</p> 	<p>1/4" ventil s vnějším závitem NPT 29452.1</p> 	<p>1/4" Y rozdvojka 49428.1</p> 
<p>1/4" hrdlo se závitem NPT 1/4" 49426.1</p> 	<p>1/4" hrdlo se závitem NPT 1/8" 49425.1</p> 	<p>1/4" tryska 90° Ø 1,59 49439.1</p> 	<p>1/4" tryska 90° Ø 3,18 49440.1</p> 

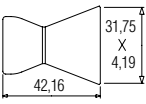
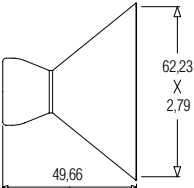
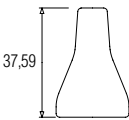
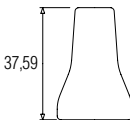
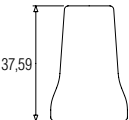
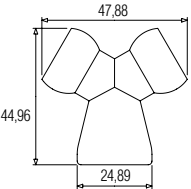
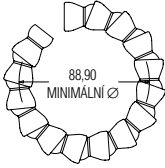
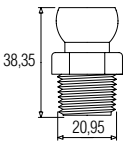
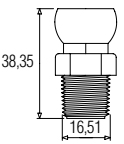
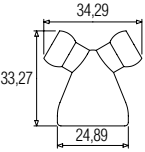
<p>1/4" tryska 90° Ø 6,35 49441.1</p>	<p>1/4" tryska Ø 1,59 49422.1</p>	<p>1/4" tryska Ø 3,18 49423.1</p>	<p>1/4" tryska Ø 6,35 49424.1</p>
			
<p>1/4" 10 segmentů 49421.1</p>		<p>1/4" segmenty 49421.1</p>	<p>1/4" koleno 49435.1</p>
			
<p>1/4" proudová tryska 49456.1</p>	<p>1/4" plochá tryska 49427.1</p>	<p>1/4" 41475 49445.1 & 49446.1</p>	
			
<p>1/4" naklápěcí 20ti tryska 49455.1</p>	<p>1/4" naklápěcí 16ti tryska 49450.1</p>	<p>1/4" naklápěcí 16ti tryska 49449.1</p>	
			

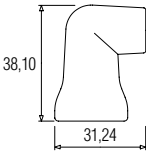
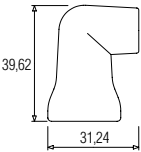
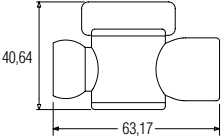
1/2" HADICE PODROBNÉ ROZMĚRY

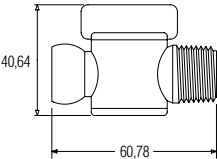
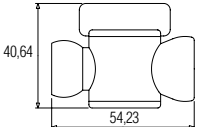
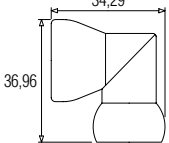
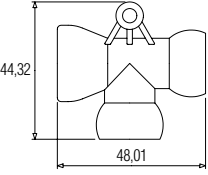
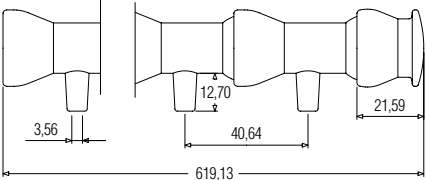
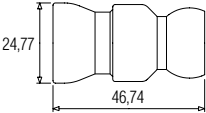
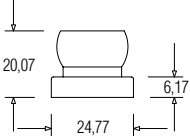
<p>1/2" rozprašovací 7mi tryska 59893.1</p> 	<p>1/2" rozprašovací 5ti tryska 59892.1</p> 	<p>1/2" štěrbinová tryska 3,18 59891.1</p> 	<p>1/2" štěrbinová tryska 2,03 59890.1</p> 
<p>1/2" proudová tryska 59897.1</p> 	<p>1/2" proudová tryska 59898.1</p> 	<p>1/2" proudová tryska Ø 31,75 59867.1</p> 	<p>1/2" plochá tryska 59871.1</p> 
<p>1/2" tryska Ø 6,35 59866.1</p> 	<p>1/2" tryska Ø 9,53 59862.1</p> 	<p>1/2" tryska Ø 12,70 59863.1</p> 	<p>1/2" Y rozvojka 59868.1</p> 
<p>1/2" segmenty 59861.1</p> 	<p>1/2" hrdlo se závitem NPT 1/2" 59865.1</p> 	<p>1/2" hrdlo se závitem NPT 3/8" 59864.1</p> 	<p>1/2" Y rozvojka z 1/2" na 1/4" 59870.1</p> 
<p>1/2" tryska 90° Ø 6,35 59878.1</p> 	<p>1/2" tryska 90° Ø 9,53 59879.1</p> 	<p>1/2" tryska 90° Ø 12,70 59880.1</p> 	<p>1/2" ventil s vnitřním závitem NPT 39853.1</p> 

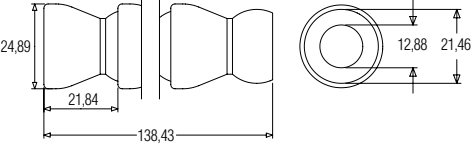
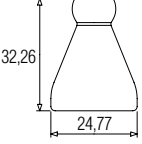
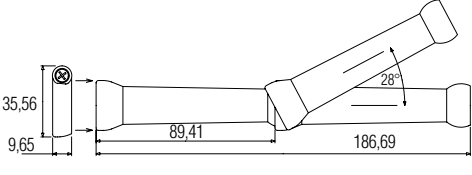
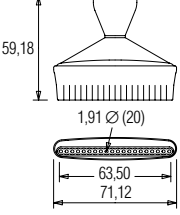
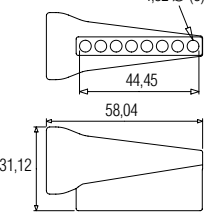
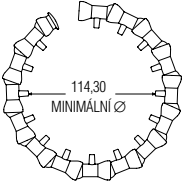
<p>1/2" ventil s vnějším závitem NPT 39852.1</p> 	<p>1/2" mezisegmentový ventil 39854.1</p> 	<p>1/2" koleno 59874.1</p> 	<p>1/2" T redukce 59875.1</p> 
<p>1/2" sada bočních trysek 51837</p> 		<p>1/2" jednosměrný průtokový ventil 39851.1</p> 	<p>1/2" přípojka na hadici 59896.1</p> 
<p>1/2" spojka (1/2":1/2") 59872.1</p> 	<p>1/2" 6 segmentů 59861.1</p> 		<p>1/2" redukce na 1/4" 59869.1</p> 
<p>1/2" 51835 59883.1 & 59884.1</p> 		<p>1/2" naklápečí 20ti tryska 59895.1</p> 	<p>1/2" tryska 90° plochá 59881.1</p> 
<p>1/2" sada bočních trysek 51837.1</p> 			

3/4" HADICE PODROBNÉ ROZMĚRY

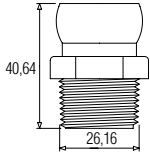
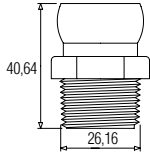
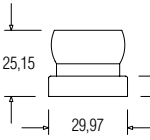
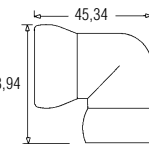
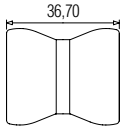
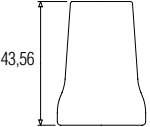
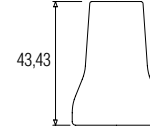
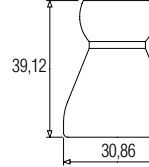
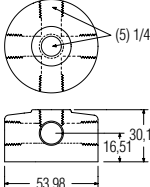
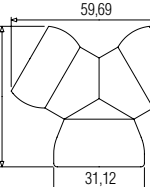
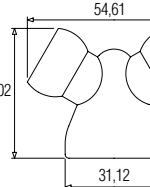
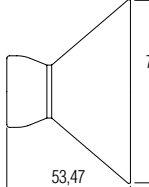
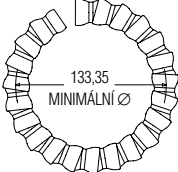
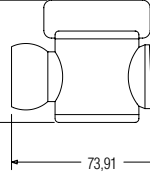
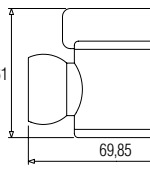
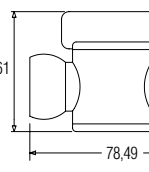
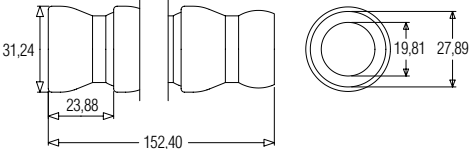
<p>3/4" hrdlo se závitem NPT 3/4" 69545.1</p>	<p>3/4" hrdlo se závitem BSPT 3/4" 69549.1</p>	<p>3/4" přípojka na hadici 60533.1</p>	<p>3/4" koleno 69555.1</p>
			
<p>3/4" spojka (3/4":3/4") 69554.1</p>	<p>3/4" tryska Ø 19,05 mm 69542.1</p>	<p>3/4" tryska Ø 15,88 mm 69543.1</p>	<p>3/4" redukce na 1/2" 69548.1</p>
			
<p>1/4" magnetická základna k rozvaděči 40400.1</p>	<p>3/4" Y rozvodjka 69551.1</p>	<p>3/4" Y redukce z 3/4" na 1/2" 69552.1</p>	<p>3/4" plochá tryska 69547.1</p>
			
<p>3/4" segmenty 69541.1</p>	<p>3/4" ventil s vnějším závitem NPT 69556.1</p>	<p>3/4" mezisegmentový ventil 69558.1</p>	<p>3/4" ventil s vnitřním závitem NPT 69557.1</p>
			
<p>3/4" 6 segmentů 69541.1</p>			
			

2 1/2" SACÍ HADICE

Kat. ozn. Popis



81201 Sady 2 1/2" segmentů
9 ks segmentů
81301AS 9 ks segmentů antistat.
81202 18 ks segmentů
81302AS 18 ks segmentů antistat.



81203.1 2 1/2" kulatá tryska Ø 11,43 cm
81303AS.1 2 1/2" kulatá tryska antistat. Ø 11,43 cm



81204.1 2 1/2" obdélníková tryska (15,24x8,89 cm)
81304AS.1 2 1/2" obdélníková tryska antistat. (15,24x8,89 cm)



81205.1 2 1/2" oválná tryska
81305AS.1 2 1/2" oválná tryska antistat.



81206.1 2 1/2" PVC adaptér Ø 7,62 cm
* nevyrábí se v antistat. provedení



81207.1 2 1/2" adaptér Ø 7,62 cm
81307AS.1 2 1/2" adaptér antistat. Ø 7,62 cm



81208.1 2 1/2" ventil
81308AS.1 2 1/2" ventil antistat.



81209.1 2 1/2" adaptér s montážní přípojkou



81210.1 2 1/2" adaptér pro průmyslový odsavač



oválná tryska kónická 81205.1	segment 81201	PVC adaptér 81206.1	adaptér pro plechovou trubku 81207.1
ventil s posuvným uzávěrem 81208.1	adaptér 81209.1	adaptér 81210.1	

CHLADICÍ SYSTÉMY NOGA

CHLAZENÍ MINICOOL





Chlazení mlhou

TYP	POČET SEGMENTŮ	DĚLKA
MC1400	14	264 mm
MC1900	19	334 mm
MC2900	29	479 mm



- Silný magnet pro upevnění
- Možnost přepínání na vzduch a chladicí kapalinu
- Ohebný převod s nastavitelnou tryskou
- Hadice z nerez oceli
- Provedení jednoduché, pevné a masivní

Skládá se:

MC0101 MC0102 MC0103	Rozprašovací hadice 	14 segmentů délka 270 mm 19 segmentů délka 340 mm 29 segmentů délka 485 mm
MC0380 MC0302	Hadice pro přívod vzduchu 	délka 1 m délka 2 m
MC0360 MC0311	Hadice pro přívod chladicí kapaliny 	délka 1 m délka 2 m
MC0140 NF0037	Permanentní magnet Přepínatelný magnet 	upínací síla 280 N upínací síla 320 N
MC0120	Vzduchový ventil 	

CHLAZENÍ COBRA

Dávkové vstřikování chladicí kapaliny

- Vystřelování jednotlivých kapek mechanicky nebo automatickými impulsy
- Místo kapek možno použít rozprašování
- Použitím přidavného ventilu možnost očištění pracovní plochy tlakem vzduchu

COBRA 2000 je poháněna tlakem vzduchu a tlaku 3–9 barů. Mohou být použity tekutiny a rozprašovačla do viskozity 250 cst.



Možnosti zapojení:

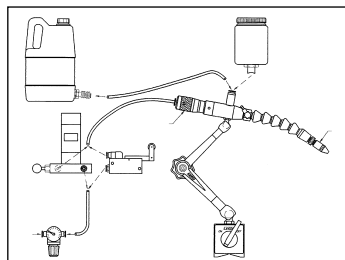

A: jednotlivé kapky

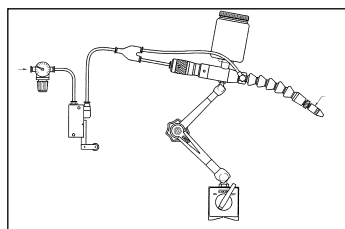

B: rozprašování jednotlivé kapky

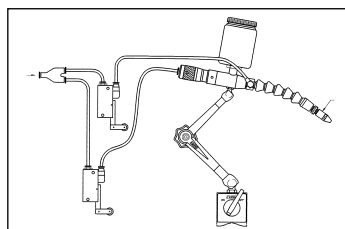

C: kapky a vzduch nezávisle

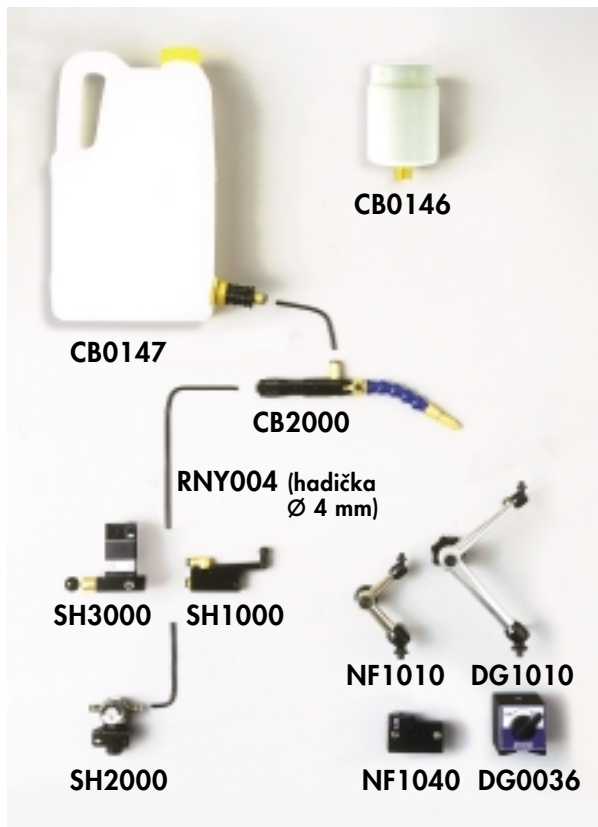

NOGA DÁLE DODÁVÁ odjehlovací systém

ŠKRABÁK NOGA 3 NG1003

Univerzálně použitelný.

Skládá se: NG-1 rukojeť, nože S10, S20 a S35.

ŠKRABÁK NOGA 5 NG1005

Obdoba NG1003, ale s 2 noži navíc.

Skládá se: NG-1 rukojeť, nože S10, S20, S35, S101 a S202.

TELE „S“ ŠKRABÁK NG3003

Vhodný pro větší záběry. Upne všechny nože typu S (Ø 3,2 mm).

Skládá se: NG-3 rukojeť, S nástavec, nože S100, S20 a S30.



RUKOJETI

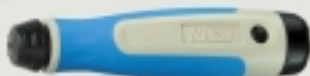

NG-1 Rukojeť NG1000

NG-1 rukojeť upne všechny nože typu S (Ø 3,2 mm). Úložný prostor pro náhradní nože. Poskytuje maximální komfort pro Vaši ruku.

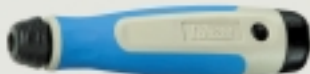

NG-3 Rukojeť NG3000

NG-3 rukojeť upne všechny nástavce. Úložný prostor pro náhradní nože. Poskytuje maximální komfort pro Vaši ruku.

NÁSTAVEC



S Nástavec EL02003

Upíná nože typu S (Ø 3,2 mm). Nástavec je teleskopický od 30–115 mm.

Délka: 131 mm.

KOMPLETNÍ KATALOG ZÍSKÁTE U SVÉHO PRODEJCE

OBSAH



TECHNICKÉ INFORMACE 3

1/4“ HADICE – 1/4“ VNITŘNÍ PRŮMĚR 4–5

1/2“ HADICE – 1/2“ VNITŘNÍ PRŮMĚR 6–7

3/4“ HADICE A DOPLŇKY 8

DOPLŇKY 9

1/4“ HADICE – PODROBNÉ ROZMĚRY 10–11

1/2“ HADICE – PODROBNÉ ROZMĚRY 12–13



3/4“ HADICE – PODROBNÉ ROZMĚRY 14

2 1/2“ SACÍ HADICE 15

CHLADICÍ SYSTÉMY NOGA 16–17



NOGA DÁLE DODÁVÁ – ODJEHLOVACÍ SYSTÉM 18